

Weather Station Compact WSC11

Instruction for Use

4.9056.1x.00x, 4.9056.10.701, 4.9056.10.801

from software version V4.08 Status: 05/2024



Dok. No. 021774/05/24

THE WORLD OF WEATHER DATA

Safety Instructions

- Before operating with or at the device/product, read through the operating instructions. This manual contains instructions which should be followed on mounting, start-up, and operation. A non-observance might cause:
 - failure of important functions
 - endangerment of persons by electrical or mechanical effect
 - damage to objects
- Mounting, electrical connection and wiring of the device/product must be carried out only by a qualified technician who is familiar with and observes the engineering regulations, provisions and standards applicable in each case.
- Repairs and maintenance may only be carried out by trained staff or **Adolf Thies GmbH & Co. KG**. Only components and spare parts supplied and/or recommended by **Adolf Thies GmbH & Co. KG** should be used for repairs.
- Electrical devices/products must be mounted and wired only in a voltage-free state.
- **Adolf Thies GmbH & Co KG** guarantees proper functioning of the device/products provided that no modifications have been made to the mechanics, electronics or software, and that the following points are observed:
 - All information, warnings and instructions for use included in these operating instructions must be taken into account and observed as this is essential to ensure trouble-free operation and a safe condition of the measuring system / device / product.
 - The device / product is designed for a specific application as described in these operating instructions.
 - The device / product should be operated with the accessories and consumables supplied and/or recommended by **Adolf Thies GmbH & Co KG** .
 - Recommendation: As it is possible that each measuring system / device / product may, under certain conditions, and in rare cases, may also output erroneous measuring values, it is recommended using redundant systems with plausibility checks for **security-relevant applications**.

Environment

- As a longstanding manufacturer of sensors Adolf Thies GmbH & Co KG is committed to the objectives of environmental protection and is therefore willing to take back all supplied products governed by the provisions of "*ElektroG*" (German Electrical and Electronic Equipment Act) and to perform environmentally compatible disposal and recycling. We are prepared to take back all Thies products concerned free of charge if returned to Thies by our customers carriage-paid.
- Make sure you retain packaging for storage or transport of products. Should packaging however no longer be required, please arrange for recycling as the packaging materials are designed to be recycled.



Documentation

- © Copyright **Adolf Thies GmbH & Co KG**, Göttingen / Germany
- Although these operating instructions have been drawn up with due care, **Adolf Thies GmbH & Co KG** can accept no liability whatsoever for any technical and typographical errors or omissions in this document that might remain.
- We can accept no liability whatsoever for any losses arising from the information contained in this document.
- Subject to modification in terms of content.
- The device / product should not be passed on without the/these operating instructions.

Table of contents

1	Device Versions	5
2	Application	5
3	Setup and Mode of Operation	6
4	Installation and Selection of Installation Site	9
4.1	Selection of installation site	9
4.2	Mechanical Mounting.....	9
4.2.1	North Alignment	12
4.3	Electrical Mounting	12
4.3.1	Cable, Cable Preparation, Connector Installation	13
4.4	Connecting Diagram.....	14
4.4.1	Connection using 5-core cable 510023 / 510024 / 510197 optional accessory..	15
4.4.2	Connection using 8-core cable 509584 / 509585 optional accessory	15
5	Maintenance	16
6	Interface.....	17
6.1	Command Interpreter THIES	17
6.1.1	Data Telegrams	19
6.2	Command Interpreter MODBUS RTU.....	25
6.2.1	Measuring Values (Input Register)	26
6.2.2	Commands (Holding Register)	32
6.3	Commands and Description	33
6.3.1	Command AI	34
6.3.2	Command BR	34
6.3.3	Command CI.....	35
6.3.4	Command DC	35
6.3.5	Command DO	36
6.3.6	Command FB.....	36
6.3.7	Command FP.....	37
6.3.8	Command FW.....	38
6.3.9	Command HP	38
6.3.10	Command ID.....	39
6.3.11	Command IP.....	40
6.3.12	Command IS.....	41
6.3.13	Command KY	41
6.3.14	Command LC.....	42
6.3.15	Command RH.....	42
6.3.16	Command RS	43
6.3.17	Command SF.....	43
6.3.18	Command SH	44
6.3.19	Command SP	45
6.3.20	Command SV	45
6.3.21	Command TR	46
6.3.22	Command TT.....	46
6.3.23	Command TZ.....	47
7	LED Signals	48
8	Specifications.....	49

9	Dimensional Drawing	52
10	Accessories (optional).....	53
11	More Information / Documents as download	53
12	EC-Declaration of Conformity	54
13	UK-CA-Declaration of Conformity	55

Tables

Table 1 : Status Word.....	20
Table 2 : Measured Value Telegram.....	22
Table 3 : Sensor Data Telegram.....	23
Table 4: Measured Value Telegram 3.....	25
Table 5 : MODBUS Frame	25
Table 6: MODBUS Exceptions	26
Table 7 : MODBUS Input Register.....	31
Table 8 : List of Commands.....	33

Figures

Figure 1: elevation angle	6
Figure 2: Diagram, evaluation characteristic position of the sun	7
Figure 3: LED signals	48
Figure 4: Spectrum of Brightness Sensors	51
Figure 5: Spectrum for Global Irradiance Sensor.....	52

Instructions for use

These instructions for use describe all application and adjustment options for the device.

These detailed instructions allow users to modify the factory settings to their needs via the serial interface of the Weather Station Compact WSC11.

Scope of supply

- 1 Weather Station Compact WSC11
- 1 Copy of the short instructions for uses

The instructions for use are available for download under the following link:

https://www.thiesclima.com/db/dnl/4.9056.10.x0x_WSC11_eng.pdf

For assisting the parameter settings and/or special configurations there is our cost-free Device Utility Tool art.-no. 9.1700.81.000 available for download on our homepage. Please download the tool with following link.

Link: <https://www.thiesclima.com/de/Download/>

In the section "General", the program "Thies Device Utility".

1 Device Versions

Designation	Order No.	Output terminal	Data format	Operating voltage
WEATHER STATION COMPACT WSC11	4.9056.10.000	1 x RS485	Data in ASCII format (command interpreter: THIES)	18...30V DC 18...28V AC
WETTERSTATION COMPACT WSC11	4.9056.10.001	1 x RS485	Data in binary format (command interpreter: MODBUS RTU)	18...30V DC 18...28V AC
WETTERSTATION COMPACT WSC11	4.9056.10.701	Identical to 4.9056.10.001 with following special settings: ID10		
WETTERSTATION COMPACT WSC11	4.9056.10.801	Identical to 4.9056.10.001 with following special settings: BR=192, ID =30, TT=0, SH= 3001		
WETTERSTATION COMPACT WSC11 with: - Precipitation quantity and intensity - Weather condition	4.9056.11.001	1 x RS485	Data in binary format (command interpreter: MODBUS RTU)	18...30V DC 18...28V AC

2 Application

The WEATHER STATION COMPACT WSC11 is designed for use in building services automation systems (e.g. shade protection control). The WSC11 features the following measured variables:

- Wind speed
- Wind direction
- 4 x brightness (north / east / south / west)
- Twilight
- Global irradiance
- Precipitation (Status, intensity and quantity)
- Weather condition (Ice, snow, frost)
- Air temperature
- Absolute air pressure
- Relative air pressure
- Time / date
- Geostationary data (local altitude, longitude and latitude)
- Position of the sun (elevation / azimuth)
- Relative air humidity
- Absolute humidity
- Dew-point temperature
- Inside temperature of housing

The interface to the device is digital and consists of an RS485 interface in half-duplex mode. Together with ID-based communications the interface allows the Weather Station to be operated in a bus. Two data protocols are available:

- ASCII (THIES- format)
- Binary (MODBUS RTU)

3 Setup and Mode of Operation

Wind Speed / Wind Direction

Wind measurement is based on the hot wire principle. The underside of the housing is equipped with a heated cylindrical sensor. A PID controller adjusts the temperature of the cylinder to a temperature that is constantly increased in relation to the environment. The supplied heat energy is a measure of wind speed.

The metal cylinder contains four temperature-measuring resistors. These resistors are thermally coupled with the cylinder and positioned according to the 4 points of the compass.

When an incident flow affects the cylinder as a function of the wind direction, this is accompanied by a temperature gradient which is registered by the measuring resistors. The relationships between the 4 temperature values are used to calculate the wind direction.

In case the wind direction cannot be determined because the wind velocity is 0m/s, the value is set to 0. Wind from the north is displayed with 360°.

Brightness

The brightness measurement is carried out via 4 Silicon photo sensors, which are aligned to the 4 cardinal directions in the mean elevation angle. Please see figure 1. The evaluation characteristic depending on the position of the sun, please see figure 2 (diagram).

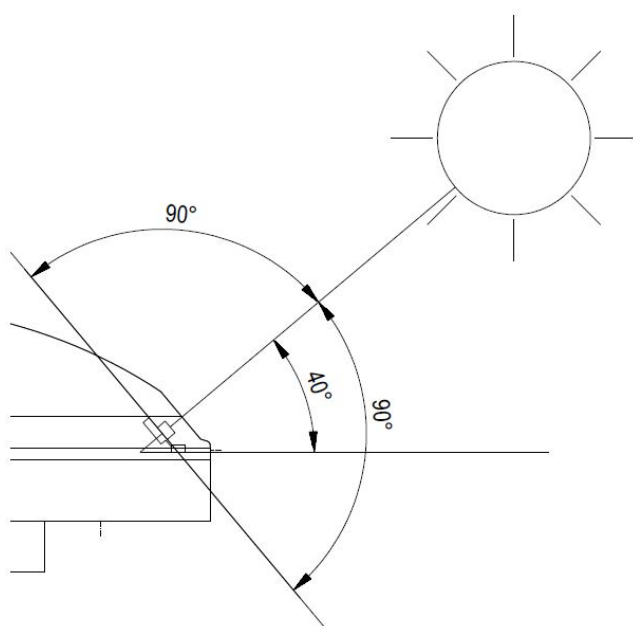

Figure 1: elevation angle

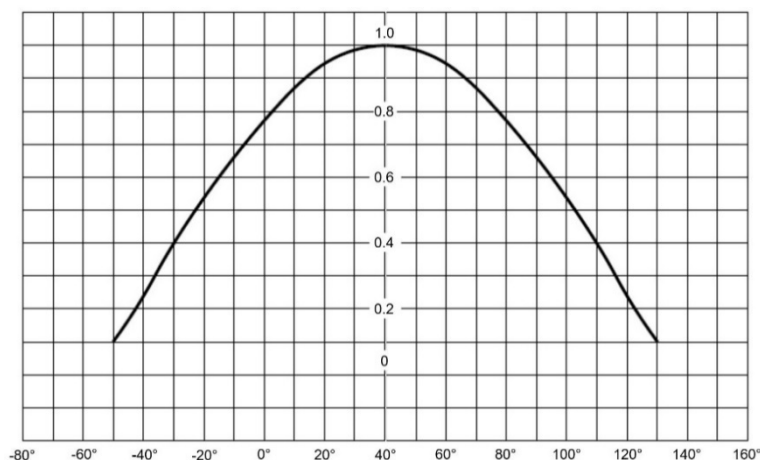

Figure 2: Diagram, evaluation characteristic position of the sun

Please see additional Figure 4: Spectrum of Brightness Sensors

Twilight

Twilight means the light diffusion in the atmosphere, which arises with the smooth transition between day and night before the beginning or after the end of day.

i.e., the solar disc is not visible.

The twilight is direction-independent.

It is calculated from the sum of the 4 measuring values of the direction-independent brightness sensors.

A change to the mean value from the 4 brightness values is possible by command.

Global irradiance

A silicon PIN photodiode is used to measure global irradiance. The sensor is positioned horizontally and registers the diurnal values of the solar irradiation intensity.

Please see additional Figure 5: Spectrum for Global Irradiance Sensor.

Precipitation

The detection of precipitation is based on capacitance measurement, i.e. the capacity of the sensor surface varies when wet. The sensor is installed in the housing cover. An integrated heating system adjusts the sensor area to an overtemperature in relation to the ambient temperature. This overtemperature (approx. 2K) prevents bedewing of the sensor surface. The thermal output is increased with precipitation. This accelerates drying of the sensor, allowing the time at which precipitation ended to be identified more accurately.

The determination of the precipitation intensity and thus also the precipitation quantity, is based on the evaluation of the capacity change. The precipitation quantity is added up to a maximum value of 9999.99 mm, after that it starts again at 0.

The **Weather condition** is an indicator calculated from current and past measured variables that shows current winter conditions. The calculation includes precipitation events from the last 12 hours, as well as the current temperature and the current precipitation status. Depending on these conditions, current snowfall, frost and ice conditions are indicated. This function proves useful for building control. Initial values are used that have proven to be suitable for this application.

Air temperature

A PT1000 measuring resistor is used to measure the air temperature. The sensor is mounted on a flexible printed board and positioned in the lower section of the housing.

Air pressure

Absolute air pressure is measured with a piezoresistive MEMS sensor.

To make a meaningful comparison between air pressure values simultaneously measured at different locations, **they need to be converted to a common datum (height above sea level)**. The calculation is referred to the height above sea level (QNH) according to the international altitude formula (DIN ISO2533).

$$p(h) = p_b \left(1 + \frac{\beta}{T_b} \cdot h\right)^{-\frac{g_n}{\beta \cdot R}}$$

P_h = air pressure at local altitude

P_b = air pressure at height above sea level

β = -0065K/m

g_n = 9.80665m/s²

R = 287.05287m²/K/s²

T_b = 288.15K

The station height, required for the calculation, can be entered manually by the **Command SH**, or can be determined automatically by GPS.

If you want to achieve an accuracy of 0.1hPa, referred to sea level, the local altitude (altitude of the baro transmitter) must be given up to an accuracy of 0.8m.

Time / date and geostationary data

The Weather Station has a GPS receiver with a built-in RTC. This allows it to receive the position of the Weather Station (degree of longitude/latitude, local altitude) time (UTC) and date. The GPS receiver does not need alignment.

The built-in RTC (Real Time Clock) is buffered with a backup capacitor and retains its data without a voltage supply for a period of minimum 3 days.

Position of the sun (elevation / azimuth)

On the basis of the GPS data the current sun position is calculated every second.

Humidity measurement

A built-in hygro-thermosensor is used to measure humidity levels. The sensor has a small air exchange volume thanks to its compact design and responds to changes in humidity in seconds.

A software module uses the relative humidity and air temperature to calculate absolute humidity and the dew-point temperature.

Inside temperature of housing

A silicon temperature sensor measures the temperature inside the housing.

GPS-Receiver

The weather station has a GPS receiver with integrated RTC (Real Time Clock) for receiving the position of the weather station, and time + date (UTC).

An alignment of the GPS receiver is not necessary.

The integrated RTC is buffered for a period of 3 days.

General information:

After activation of the WSC11 the first satellite data are available after approx. 2.5min.

When receiving the signals from one satellite: time with an accuracy of $< 1\mu\text{s}$.

When receiving the signals from three satellites: position with an accuracy of $< 20\text{m}$

When receiving the signals from four satellites: altitude, referred to the WGS84-ellipsoid, with an accuracy $< 30\text{m}$

4 Installation and Selection of Installation Site

Please note:

The working position of the COMPACT WSC11 Weather Station is horizontal (plug connection underneath).

During installation, de-installation, transport or maintenance of the COMPACT WSC11 Weather Station make sure that no water gets into the device and connector.

4.1 Selection of installation site

An exposed position should be selected for this site. Measurement properties should not be influenced by light reflections, cast shadows or the device being positioned in the lee of the wind. Protection against lightning and overvoltages should also be provided by the customer.

4.2 Mechanical Mounting

The intended installation of the Weather Station WSC11 requires the use of a pipe socket / pipe with an **outside diameter of $\leq 25\text{mm}$** . The **inside diameter must be $\geq 19\text{mm}$** to admit the connector and cable.

Tool:

Hexagon socket wrench SW2mm
(socket wrench).

Procedure:

1. Push cable/plug connection through the bore hole of the mast, tube, bracket etc.
2. Put WSC11 on mast, tube.
3. Align WSC11 to "north". (**Procedure see chapter 4.2.1**).
4. Secure WSC11 by the M4- hexagon socket screw.

Attention:

The hexagon socket screw is to be tightened by max. 0.6Nm.

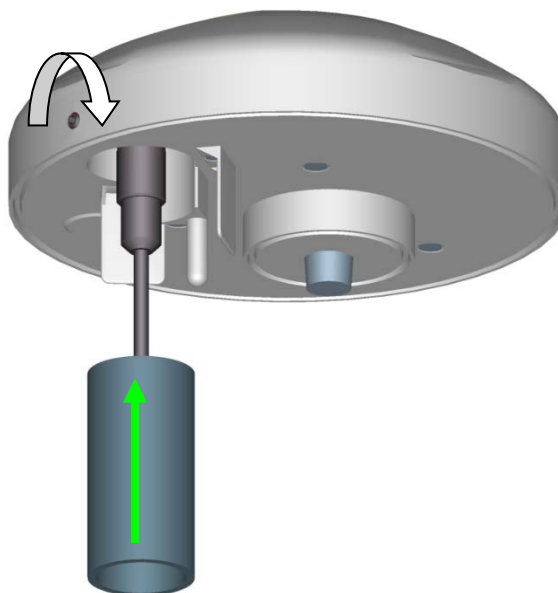

When using the **mounting angel article no. 509564** (see chapter accessories) the **guide angles must be removed**, see fig.

The mounting angle is not included in delivery.

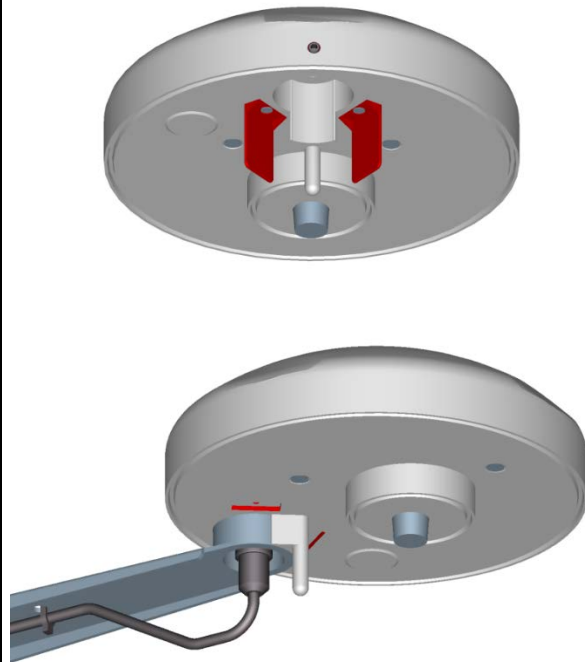

Remark: Tube and mounting angle are not included in delivery.

4.2.1 North Alignment

For the exact determination of wind- and brightness direction the WEATHER STATION COMPACT WSC11 must be mounted in **north alignment** (geographic north).

The hexagon socket screw **serves as north marking (N)**

Tool:

Hexagon socket wrench SW2mm (socket wrench).

Procedure:

1. Detect a prominent object in the surrounding area (tree, building etc.) in north direction by means of a compass.
2. Via the north marking (N) and an imaginary north-south axis the weather station is to be located on the prominent object.
3. Align weather station. The north marking must indicate to the geographic north.
4. In case of match the weather station is to be secured by an M4-hexagon socket screw.

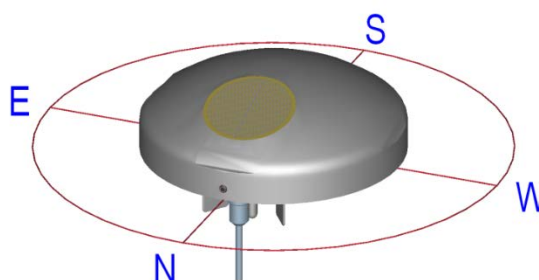

Attention:

The hexagon socket screw is to be tightened by max. 0.6Nm.

Remark:

With the north alignment by means of a compass, the local variation (deviation in direction of a compass needle from the true north direction) by interfering magnetic fields, and magnetic field influences by hardware and electric cable are to be considered.

4.3 Electrical Mounting

The COMPACT WSC11 Weather Station is equipped with a 7-pin plug for electrical connection. A cable socket (mating connector) is included in the scope of supply.

4.3.1 Cable, Cable Preparation, Connector Installation

The cable to be used for connection should have the following properties:

5 cores, core cross-section max. 0.14mm², cable diameter max. 5.0mm, resistant to ultraviolet rays, overall shielding.

Note:

A prepared connecting cable is available for the COMPACT WSC11 Weather Station as an optional accessory.

Cable socket, type: Binder, series 711

Achtung: max. Drehmoment des Gewinderings im Flanschsteckverbinder: 50cNm (handfest)
Attention: max. torque of ring nut in socket connector: 50cNm (manual adjustment)

Cable socket, type: Binder, series 712

1. Bead pressing screw, pinch ring, seal and snap bush to cable.
2. Dismantle cable to min. 10 and max 12 mm length.
3. Strip and solder single wires.
4. Screw snap bush with contact insert.
5. Push the assembled part into the coupling ring and screw the coupling ring with the snap bush.
6. Push seal and pinch ring into snap bush and tighten pressing screw.
7. Snap coupling ring onto snap bush.

Attention:

The voltage drop on the cable must be taken into consideration with long cable connections, so that the supply voltage for the WEATHER STATION COMPACT WSC11 is guaranteed.

Calculation of the voltage drop on the cable. $U_{Ltg} = R_L \cdot I$; $R = 2 \cdot l \cdot \rho / A$; ρ (rho) = 0,018

Example: $I = 0,3A$, $A = 0,14mm^2$, $L = 100m$

$R = 2 \cdot l \cdot \rho / A$, $R = 25,7\Omega$

$U_{Ltg} = R_L \cdot I$, $U_{Ltg} = 7,7V$

4.4 Connecting Diagram

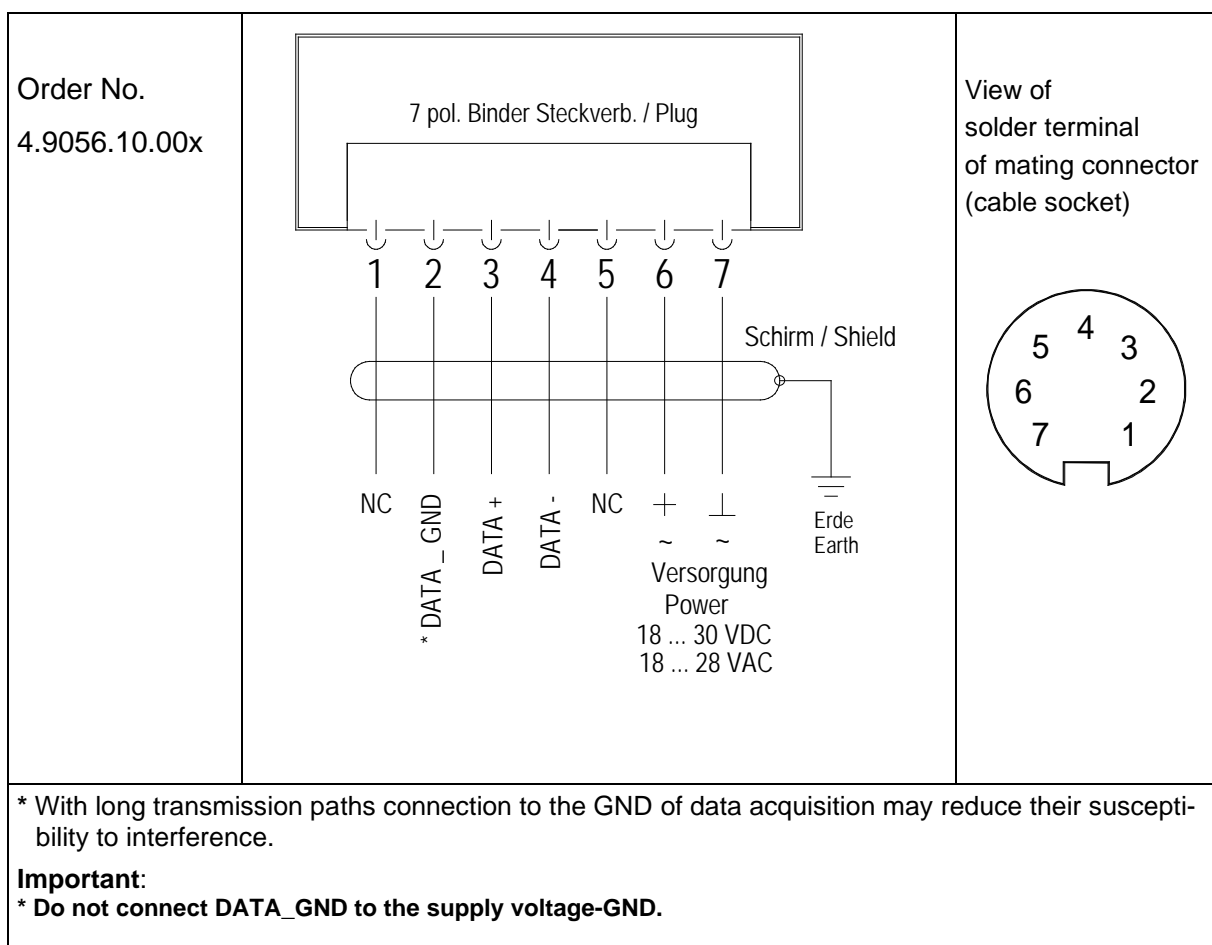

4.4.1 Connection using 5-core cable 510023 / 510024 / 510197 optional accessory

PIN	Core colour	Function
1		NC
2	WHITE	* DATA _ GND
3	BROWN	DATA +
4	GREEN	DATA -
5		NC
6	YELLOW	+ power 18...30V DC / 18...28V AC
7	GRAY	- power 18...30V DC / 18...28V AC

Difference to part no. 509584/509585, 5 cores.
 * With long transmission paths connection to the GND of data acquisition may reduce their susceptibility to interference.
Important:
 * Do not connect DATA_GND to the supply voltage-GND.

4.4.2 Connection using 8-core cable 509584 / 509585 optional accessory

PIN	Core colour	Function
1	WHITE	NC
2	BROWN	* DATA _ GND
3	GREEN	DATA +
4	YELLOW	DATA -
5	GREY	NC
6	PINK	+ power 18...30V DC / 18...28V AC
7	BLUE	- power 18...30V DC / 18...28V AC
-	RED	NC

Difference to part no. 510023/510024, 8 cores, three not connected (NC).
 * With long transmission paths connection to the GND of data acquisition may reduce their susceptibility to interference.
Important:
 * Do not connect DATA_GND to the supply voltage-GND.

Note:

The RS485 converter or RS485/USB converter should have the following characteristics:

- **RS485 converters should be used that do NOT have automatic marking between half and full duplex operation.**
- **Switching should be done manually via jumper.**
- **Furthermore, it must be possible to set PullUp and PullDown resistors (BIAS resistors) on the interface converter.**
- **The meaning of the bus terminating resistor is subordinated to the BIAS resistors.**
- **Data_GND should be included.**

5 Maintenance

As the device does not have any moving parts, i.e. is not subject to wear during operation, only minimal servicing is required.

Depending on the location the instrument might pollute. The cleaning should be carried out by means of water and a soft cloth. Aggressive cleaning agents must not be used.

Please note:

During storage, installation, de-installation, transport or maintenance of the COMPACT WSC11 Weather Station make sure that no water gets into the device or connector.

We recommend the following procedure for humidity calibration:

1. Storage of the device for several hours at rather low humidity levels
2. Carrying out the calibration in accordance with DKD guideline 5-8 "Calibration of hygrometers for direct measurement of relative humidity"; Procedure A1, A2, B1 or B2
3. Consideration of the adjustment time also according to the DKD guideline 5-8 "Calibration of hygrometers for the direct recording of the relative humidity"

6 Interface

The interface to the Weather Station consists of a RS485 link (half-duplex mode), with the following data format:

- 9600baud (the baud rate can be selected with the **Command BR**)
- 8data bits
- No parity
- 1stop bit
- Data in ASCII format (command interpreter: THIES)
- Data in binary format (command interpreter: MODBUS RTU)

The behavior (configuration) of the Weather Station can be changed using the available commands (see **Commands and Description**). For the command interpreter Thies-type the query of the measuring values is carried out by the **Command TR** or resp. by the **Command TT**.

When the Weather Station starts up, the character string "Weather Station", software version, hardware version and serial number is output:

```
Weather Station
v03.04
508990 v11-11
12030123
```

6.1 Command Interpreter THIES

The Weather Station is equipped with a command interpreter of THIES-type, which can be used to change the behaviour of the device. This allows you for example to adjust the averaging periods for wind speed and wind direction. Commands basically have the following structure:

- `<id><command><CR>` (No parameter: used to interrogate the selected parameter).
- `<id><command><parameter><CR>` (With parameter: used to set a new parameter).

`id:` identification number ("00" to "99")
`command:` command encompassing 2 characters (see list of commands)
`parameter:` parameter value with between 1 to 10 positions (decimal value in ASCII format)
`<CR>:` carriage return (13_{dec}; 0x0D)

The 'id' identification number allows several devices to be operated together in a bus system. Every device is assigned its own 'id' (see **Command ID**), and automatic telegram output is switched off (see **Command TT**).

A transmitted command is acknowledged with an echo telegram. The echo telegram starts with a "!" followed by the id, command and value selected. It ends with the characters "carriage return" and "new line".

Commands can be transmitted with or without a parameter. If no parameter is specified, the set value will be output.

Example: 00BR<CR>
 !00BR00005<CR>

If a command is transmitted with a parameter, the parameter is verified. If it is valid, it will be saved and specified in the echo telegram. If the parameter is invalid, it will be disregarded and the set value output in the echo telegram.

Examples:

00BR00005<CR>	transmission command
!00BR00005<CR>	echo telegram (parameter valid and password OK)
00BR00004<CR>	transmission command
!00BR00005<CR>	echo telegram (parameter valid but key incorrect)

Note:

The values measured by the sensor can be queried with the command TR. In this case the Weather Station does not respond with the echo telegram, but with the requested data telegram!

To avoid any unintentional change in parameters, some commands (see list of commands) are protected with a password. This password must be transmitted before the actual command.

Example: Change baud rate

00KY234<CR>	Release commands of user level
00BR4<CR>	Set baud rate to 4800
!00BR00004<CR>	Baud rate set to 4800

The Weather Station supports 3 different password levels.

- User level (password: "234")
- Calibration data level
- Administrator level

Please note:

Password-protected commands are released as long as one of the following conditions is satisfied:

- ***the supply voltage is switched***
- ***command 00KY0<CR> is transmitted***
- ***no new command is transmitted for min. 120s***

6.1.1 Data Telegrams

Data output takes place in response to a request with the command TR. You can choose between the following telegrams:

- Measured value telegram (parameter=1)
- Sensor data telegram (parameter=2)

Calculation of the checksum, the composition of the status word and the control characters/separators used in the telegrams are described below.

Control Characters:

CR – Carriage return (13_{dec}; 0x0D)

LF – Line feed (10_{dec}; 0x0A)

STX – Start of text (2_{dec}; 0x02)

ETX – End of text (3_{dec}; 0x03)

Separators:

The semicolon ';' is used as the separator between the individual measured values in the string.

The checksum separator is the multiplication sign '*'.

Checksum:

The checksum is the XOR link of all characters between <STX> and the byte <*>.

The asterisk acts as the separator from the checksum and is no longer included in the checksum.

Status:

The Weather Station includes a status word (32-bit) which supplies information about the status of the Weather Station. The measured values undergo a plausibility check and are shown in the status word.

Bit number	Function	Description
Bit 0	Precipitation sensor	=1, bedewing protection active
Bit 1	Precipitation sensor	=1, drying phase of sensor surface
Bit 2	GPS data	=1, no valid RMC telegram received
Bit 3	RTC data from GPS receiver	=1, time from GPS receiver invalid
Bit 4	ADC values	=1, values from analog-digital-converter invalid
Bit 5	Air pressure	=1, measured value from air pressure sensor invalid
Bit 6	Brightness north	=1, measured value from brightness sensor north invalid
Bit 7	Brightness east	=1, measured value from brightness sensor east invalid
Bit 8	Brightness south	=1, measured value from brightness sensor south invalid
Bit 9	Brightness west	=1, measured value from brightness sensor west invalid
Bit 10	Twilight	=1, measured value for twilight invalid
Bit 11	Global irradiance	=1, measured value from global irradiance sensor invalid
Bit 12	Air temperature	=1, measured value from air temperature sensor invalid
Bit 13	Precipitation	=1, measured value from precipitation sensor invalid
Bit 14	Wind speed	=1, measured value from wind speed sensor invalid
Bit 15	Wind direction	=1, measured value from wind direction sensor is invalid
Bit 16	Humidity sensor	=1, Readings from the humidity sensor invalid (relative humidity, absolute humidity, dew point temperature)
Bit 17	Watchdog Reset	=1, last restart by watchdog reset
Bit 18	EEPROM Parameters	=1, internal EEPROM parameters invalid
Bit 19	EEPROM Parameters	=1, internal EEPROM parameters contain the Standard-values
Bit 20	New FW	=1, last restart was carried out with new firmware

Table 1 : Status Word

6.1.1.1 Measured value telegram 1

The Weather Station responds to the command "00TR1\r" with the measured value telegram. The telegram structure is given in the following table:

Position	Length	Example	Description
1	1	<STX>	Start of text characters (0x02)
2	3	WSC	Designates theWSC11 weather station
5	1	;	Semicolon
6	2	##	Identification number of weather station
8	1	;	Semicolon
9	19	dd.mm.yyyy hh:mm:ss	Date and time separated with a blank character dd: day, mm: month, yyyy: year, hh: hour, mm: minute, ss: second
28	1	;	Semicolon
29	6	#####	Specifies time format: UTC CEST CET UTC+xh
35	1	;	Semicolon
36	5	###.#	Brightness north (kLux)
41	1	;	Semicolon
42	5	###.#	Brightness east (kLux)
47	1	;	Semicolon
48	5	###.#	Brightness south (kLux)
53	1	;	Semicolon
54	5	###.#	Brightness west (kLux)
59	1	;	Semicolon
60	3	###	Twilight (Lux)
63	1	;	Semicolon
64	4	####	Global irradiance (W/m2)
68	1	;	Semicolon
69	5	###.#	Air temperature (°C)
74	1	;	Semicolon
75	1	#	Precipitation status (0: no precipitation, 1: precipitation)
76	1	;	Semicolon
77	4	##.#	Average ¹ wind speed (m/s)
81	1	;	Semicolon
82	3	###	Average ¹ wind direction (°)
85	1	;	Semicolon
86	6	####.#	Absolute air pressure (hPa)
92	1	;	Semicolon
93	6	####.#	Relative air pressure (hPa), referred to height above sea level
99	1	;	Semicolon
100	5	###.#	Inside temperature of housing (°C)
105	1	;	Semicolon
106	5	###.#	Relative humidity (% r.h.)

Position	Length	Example	Description
111	1	;	Semicolon
112	6	###.##	Absolute humidity (g/m ³)
118	1	;	Semicolon
119	5	###.#	Dew-point temperature (°C)
124	1	;	Semicolon
125	11	####.#####	Degree of longitude (°) (GPS position) Positive sign for longitude in eastern direction Negative sign for longitude in western direction
136	1	;	Semicolon
137	10	###.#####	Latitude (°) (GPS position) Positive sign for latitude in northern direction Negative sign for latitude in southern direction
147	1	;	Semicolon
148	5	###.#	Position of the sun, elevation or resp. elevation angle (°) On sunrise and sunset elevation equals 0° Between these distinctive points (i.e. intraday) the elevation takes positive values
153	1	;	Semicolon
154	5	###.#	Position of the sun, azimuth or resp. geographic direction (°) The azimuth is counted positively from the north to the south 0° = north ; 180° = south
159	1	;	Semicolon
160	8	#####	32-bit sensor status in hexadecimal format (0000 – FFFFFFFF)
168	1	*	Asterisk as separator for checksum
169	2	##	8-bit checksum in hexadecimal format (00 – FF). The checksum is calculated from the exclusive OR link of all characters after STX to the character before "**"
171	1	<ETX>	End of text characters (0x03)
172	1	<CR>	Carriage return (0x0D)
173	1	<LF>	Line feed (0x0A)

Table 2 : Measured Value Telegram

1: The averaging interval is selected with the **Command AI**.

Measured values

The measured values are 1-second average values, with the exception of wind speed and wind direction.

If the specified measuring range is exceeded, the measured value is limited to the maximum (terminal value of measuring range) and the relevant bit set in the status (see **table 1: Status world**).

6.1.1.2 Sensor data telegram 2

The Weather Station responds to the command "00TR2\r" with the sensor data telegram. The telegram structure is given in the following table:

Position	Length	Example	Description
1	1	<STX> 0x02	Start of text characters
2	10	#####	Serial number
12	1	;	Semicolon
13	5	##-##	HW version (e.g. 06-11)
18	1	;	Semicolon
19	5	##.##	SW version (e.g. 01.00)
24	1	;	Semicolon
25	6	####.#	Height of Weather Station referred to height above sea level in metres, derived from the GPS data (Geoid Model)
31	1	*	Asterisk as separator for the checksum
32	2	##	8-bit checksum in hexadecimal format (00 – FF). The checksum is calculated from the exclusive OR link of all characters after STX to the character before "*"
34	1	<ETX> 0x03	End of text characters
35	1	<CR> 0x0D	Carriage return
36	1	<LF> 0x0A	Line feed

Table 3 : Sensor Data Telegram

6.1.1.3 Measured value telegram 3 (This telegram is only available with 4.9056.11.001)

The Weather Station responds to the command "00TR3\r" with the measured value telegram. The telegram structure is given in the following table:

Position	Length	Example	Description
1	1	<STX>	Start of text characters (0x02)
2	3	WSC	Designates the WSC11 weather station
5	1	;	Semicolon
6	2	##	Identification number of weather station
8	1	;	Semicolon
9	19	dd.mm.yyyy hh:mm:ss	Date and time separated with a blank character dd: day, mm: month, yyyy: year, hh: hour, mm: minute, ss: second
28	1	;	Semicolon
29	6	#####	Specifies time format: UTC CEST CET UTC+xh
35	1	;	Semicolon
36	5	####.#	Brightness north (kLux)

Position	Length	Example	Description
41	1	;	Semicolon
42	5	###.#	Brightness east (kLux)
47	1	;	Semicolon
48	5	###.#	Brightness south (kLux)
53	1	;	Semicolon
54	5	###.#	Brightness west (kLux)
59	1	;	Semicolon
60	3	###	Twilight (Lux)
63	1	;	Semicolon
64	4	####	Global irradiance (W/m2)
68	1	;	Semicolon
69	5	###.#	Air temperature (°C)
74	1	;	Semicolon
75	1	#	Precipitation status (0: no precipitation, 1: precipitation)
76	1	;	Semicolon
77	7	###.###	Precipitation intensity (mm/h)
84	1	;	Semicolon
85	6	###.##	Precipitation quantity (mm)
91	1	;	Semicolon
92	1	#	Weather condition (value bit coded, bit0: frost, bit1: Ice, Bit2: Snow)
93	1	;	Semikolon
94	4	##.#	Average ¹ wind speed (m/s)
98	1	;	Semicolon
99	3	###	Average ¹ wind direction (°)
102	1	;	Semicolon
103	6	#####.#	Absolute air pressure (hPa)
109	1	;	Semicolon
110	6	#####.#	Relative air pressure (hPa), referred to height above sea level
116	1	;	Semicolon
117	5	###.#	Inside temperature of housing (°C)
122	1	;	Semicolon
123	5	###.#	Relative humidity (% r.h.)
128	1	;	Semicolon
129	6	###.##	Absolute humidity (g/m ³)
135	1	;	Semicolon
136	5	###.#	Dew-point temperature (°C)
141	1	;	Semicolon
142	11	#####.#####	Degree of longitude (°) (GPS position) Positive sign for longitude in eastern direction Negative sign for longitude in western direction
153	1	;	Semicolon
154	10	###.#####	Latitude (°) (GPS position) Positive sign for latitude in northern direction Negative sign for latitude in southern direction
164	1	;	Semicolon
165	5	###.#	Position of the sun, elevation or resp. elevation angle (°) On sunrise and sunset elevation equals 0°

Position	Length	Example	Description
			Between these distinctive points (i.e. intraday) the elevation takes positive values
170	1	;	Semicolon
171	5	###.#	Position of the sun, azimuth or resp. geographic direction (°). The azimuth is counted positively from the north to the south 0° = north ; 180° = south
176	1	;	Semicolon
177	8	#####	32-bit sensor status in hexadecimal format (0000 – FFFFFFFF)
185	1	*	Asterisk as separator for checksum
186	2	##	8-bit checksum in hexadecimal format (00 – FF). The checksum is calculated from the exclusive OR link of all characters after STX to the character before "*"
188	1	<ETX>	End of text characters (0x03)
189	1	<CR>	Carriage return (0x0D)
190	1	<LF>	Line feed (0x0A)

Table 4: Measured Value Telegram 3

1: The averaging interval is selected with the **Command AI**.

Measured values

The measured values are 1-second average values, with the exception of wind speed and wind direction.

If the specified measuring range is exceeded, the measured value is limited to the maximum (terminal value of measuring range) and the relevant bit set in the status (see **table 1: Status world**).

6.2 Command Interpreter MODBUS RTU

Once the command interpreter is selected the transmitted bytes are interpreted according to the MODBUS specification (<http://www.modbus.org/>). Here, the weather station WSC11 is representing a MODBUS Slave.

The data transmission is carried out in packages, so-called frames, of maximum 256 bytes. Each package contains a 16bit CRC checksum (initial value: 0xffff).

Slave-Address	Function code	Data	CRC	
1byte	1byte	0...252byte(s)	2bytes	
			CRC low-byte	CRC high-byte

Table 5 : MODBUS Frame

The following MODBUS functions are supported:

- 0x04 (Read Input Register)
- 0x03 (Read Holding Registers)
- 0x06 (Write Single Register)
- 0x10 (Write Multiple Registers)

The weather station WSC11 supports a write access for the slave-address 0 (“Broadcast”).

All received MODBUS request are checked for validity before carrying out. In error case the weather station responds with one of the following exceptions (→MODBUS Exception Responses).

Code	Name	Signification
0x01	ILLEGAL FUNCTION	The function code in the request is not allowed for the register address.
0x02	ILLEGAL DATA ADDRESS	The register address in the request is not valid.
0x03	ILLEGAL DATA VALUE	The stated data in the request are not allowed.

Table 6: MODBUS Exceptions

6.2.1 Measuring Values (Input Register)

All measuring values of the weather station WSC11 consume 32Bit, i.e. 2 MODBUS register addresses. The following table shows the allocation of measuring value to register address, while the measuring values are sorted as follows:

- By measuring value type (30001 to 34999).
- In unbroken sequence (35001 to 39999).

Register address	Parameter Name	Unit	Multiplicator	Explanation	Data type
30001	Wind speed	m/s	10	value / 10 (1 decimal place, e.g. 101=10.1m/s)	U32
30003	Mean value Wind speed	m/s	10	value / 10 (1 decimal place, e.g.. 101=10.1m/s)	U32
30201	Wind direction	°	10	value/ 10 (1 decimal place, e.g. 1010=101.0°)	U32

Register address	Parameter Name	Unit	Multiplicator	Explanation	Data type
30203	Mean value Wind direction	°	10	value / 10 (1 decimal place, e.g. 1010=101.0°)	U32
30401	Air temperature	°C	10	value / 10 (1 decimal place, e.g. 255=25.5°C)	S32
30403	Interior tempera- ture of housing	°C	10	value / 10 (1 decimal place, e.g. 355=35.5°C)	S32
30601	relative humidity	%r.h.	10	value/ 10 (1 decimal place, e.g. 355=35.5°r.F.)	U32
30603	absolute humidity	g/m ³	100	value / 100 (2 decimal places, e.g. 923=9.23g/m ³)	U32
30605	Dew point temper- ature	°C	10	value / 10 (1 decimal place, e.g. 115=11.5°C)	S32
30801	Absolute air pres- sure	hPa	100	value / 100 (2 decimal places, e.g. 105000=1050.00hPa)	U32
30803	Relative air pres- sure relating to NHN	hPa	100	value / 100 (2 decimal places, e.g. 105000=1050.00hPa)	U32
31001	Global radiation	W/m ²	10	value / 10 (1 decimal place, e.g. 10000=1000.0W/m ²)	S32
31201	Brightness north	kLux	10	value / 10 (1 decimal place, e.g. 1200=120.0kLux)	U32
31203	Brightness east	kLux	10	value / 10 (1 decimal place, e.g. 1200=120.0kLux)	U32
31205	Brightness south	kLux	10	value / 10 (1 decimal place, e.g. 1200=120.0kLux)	U32
31207	Brightness west	kLux	10	value / 10 (1 decimal place, e.g. 1200=120.0kLux)	U32
31209	Twilight	Lux	1	value (no decimal place, e.g. 500=500Lux)	U32

Register address	Parameter Name	Unit	Multiplicator	Explanation	Data type
31401	Precipitation status		1	value (no decimal place, (0=no precipitation, 1=precipitation))	U32
31403	Precipitation intensity	mm/h	1000	Value / 1000 (3 decimal place, e.g. 99999=99.999mm/h)	U32
31405 ²	Amount of precipitation per day (reset at 00:00:00)	mm/d	1000	Wert / 1000 (3 decimal place, e.g. 99999=99.999mm)	U32
31409 ²	Niederschlagsmenge pro Tag (overflow at 1000.000mm)	mm	1000	Value / 1000 (3 decimal place, e.g. 99999=99.999mm)	U32
31413 ²	Weather condition		1	Value Bit coded Bit0 Frost Bit1 Ice Bit2 Schnow	U32
34601	Date		1	value (no decimal place, JJJJMMTT, e.g. 20121210=10.12.2012)	U32
34603	Time		1	value (no decimal place, HHMMSS, e.g. 121035=12:10:35)	U32
34605	Time format	h	1	value (no decimal place, offset to UTC in hours, e.g. 60=UTC+1h)	S32
34801	Longitude	°	1000000	value / 1000000 (6 decimal places, e.g.)	S32
34803	Latitude	°	1000000	value/ 1000000 (6 decimal places, e.g.)	S32
34805	Sun position Elevation	°	10	value / 10 (1 decimal place, e.g. 900=90.0°)	S32
34807	Sun position Azimuth	°	10	value / 10 (1 decimal place, e.g. 1800=180.0° / 0°=north, 180°=south, clockwise 0...360°)	S32
34809	Height above sea level	m	1	value (no decimal place, e.g. 240=240m above sea level)	U32
34811	Sensor status		1	value (no decimal place, bit coded, dep. of sensor)	U32

Register address	Parameter Name	Unit	Multiplicator	Explanation	Data type
34813	reserved				
34815	Operating time	s	1	Value (no decimal place, for ex. 255=255s)	U32
34817	Mean value of the height over MSL, received via GPS.	m	10	Value (1 decimal place, e.g. 240=24.0m above MSL)	U32
35001	Wind speed (30001) ¹	m/s	10	value / 10 (1 decimal place, e.g. 101=10.1m/s)	U32
35003	Mean value Wind speed (30003) ¹	m/s	10	value / 10 (1 decimal place, e.g. 101=10.1m/s)	U32
35005	Wind direction (30201) ¹	°	10	value/ 10 (1 decimal place, e.g. 1010=101.0°)	U32
35007	Mean value wind direction (30203) ¹	°	10	value / 10 (1 decimal place, e.g. 1010=101.0°)	U32
35009	Air temperature (30401) ¹	°C	10	value / 10 (1 decimal place, e.g. 255=25.5°C)	S32
35011	Interior temperature of housing (30403) ¹	°C	10	Value / 10 (1 decimal place, e.g. 355=35.5°C)	S32
35013	Dew point temperature (30605) ¹	°C	10	value/ 10 (1 decimal place, e.g. 115=11.5°C)	S32
35015	Rel. humidity (30601) ¹	%r.h.	10	value / 10 (1 decimal place, e.g. 355=35.5°r.h.)	U32
35017	Abs. humidity (30603) ¹	g/m ³	100	value / 100 (2 decimal places, e.g. 923=9.23g/m ³)	U32
35019	Absolute air pressure (30801) ¹	hPa	100	value / 100 (2 decimal places, e.g. 105000=1050.00hPa)	U32
35021	Rel. air pressure relating to sea level (30803) ¹	hPa	100	value / 100 (2 decimal places, e.g. 105000=1050.00hPa)	U32
35023	Global radiation (31001) ¹	W/m ²	10	value / 10 (1 decimal place, e.g. 10000=1000.0W/m ²)	S32
35025	Brightness north (31201) ¹	kLux	10	value / 10 (1 decimal place, e.g. 1200=120.0kLux)	U32
35027	Brightness east (31203) ¹	kLux	10	value / 10 (1 decimal place, e.g. 1200=120.0kLux)	U32
35029	Brightness south (31205) ¹	kLux	10	value / 10	U32

Register address	Parameter Name	Unit	Multiplicator	Explanation	Data type
				(1 decimal place, e.g. 1200=120.0kLux)	
35031	Brightness west (31207) ¹	kLux	10	value / 10 (1 decimal place, e.g. 1200=120.0kLux)	U32
35033	Twilight (31209) ¹	Lux	1	value (no decimal place, e.g. 500=500Lux)	U32
35035	Precipitation status (31401) ¹		1	value (no decimal place, (0=no precipitation, 1=precipitation))	U32
35037	Date (34601) ¹		1	value (no decimal place, JJJJMMTT, e.g. 20121210=10.12.2012)	U32
35039	Time (34603) ¹		1	value (no decimal place, HHMMSS, e.g. 121035=12:10:35)	U32
35041	Time format (34605) ¹	h	1	value (no decimal place, Offset to UTC in hours, e.g. 1=UTC+1h)	S32
35043	Longitude (34801) ¹	°	1000000	value / 1000000 (6 decimal places, e.g.)	S32
35045	Latitude (34803) ¹	°	1000000	value / 1000000 (6 decimal place, e.g.)	S32
35047	Sun position Elevation (34805) ¹	°	10	value / 10 (1 decimal place, e.g. 900=90.0°)	S32
35049	Sun position Azimuth (34807) ¹	°	10	value / 10 (1 decimal place, e.g. 1800=180.0° / 0°=north, 180°=south, clockwise 0...360°)	S32
35051	Height above sea level (34809) ¹	m	1	Wert (no decimal place, e.g. 240=240m above sea level)	U32
35053	Sensor status (34811) ¹		1	value (no decimal place, bit coded, dep. of sensor)	U32
35055	reserved				
35057	reserved				
35059	reserved				
35061	Operating time	s	1	Value (no decimal place, for ex. 24000=24000s since last reset)	U32
35063	Mean value of the height over MSL (34817) ¹ , received via GPS.	m	10	Value (1 decimal place, e.g. 240=24.0m above MSL)	U32

Register address	Parameter Name	Unit	Multiplicator	Explanation	Data type
35069	Precipitation intensity (31403) ¹	mm/h	1000	Value / 1000 (3 decimal place, e.g. 99999=99.999mm/h)	U32
35071 ²	Amount of precipitation per day (reset at 00:00:00) (31405) ¹	mm/d	1000	Wert / 1000 (3 decimal place, e.g. 99999=99.999mm)	U32
35073 ²	Precipitation quantity (overflow at 1000.000mm) (31409) ¹	mm	1000	Value / 1000 (3 decimal place, e.g. 99999=99.999mm)	U32
35075 ²	Weather condition (31413) ¹		1	Value Bit coded Bit0 Frost Bit1 Ice Bit2 Schnow	U32

Table 7 : MODBUS Input Register

¹⁾ The numbers in parentheses describe the register addresses, which mean the same measuring value. Thus, the wind speed for ex. is situated at address 30001 and at address 35001.

²⁾ Querying a register that is not supported by the device variant leads to a Modbus exception 0x02 "illegal data address".

Remark:

Due to the unbroken sequence of the measuring values, starting from address 35001, the MODBUS master can read-out all measuring values by one request!

6.2.2 Commands (Holding Register)

All commands of the weather station WSC11 consume 32Bit, i.e. 2 MODBUS register addresses, and are representing unsigned integral numbers. The following example shows the changing of the baud rate to 19200baud.

1. Set password for the user level (KY=234)

Slave address	Function code	Starting address	Number Registers	Number byte(s)	Data	CRC	
0x01	0x10	0x9C 49	0x00 02	0x04	0x00 00 00 EA	0x4F 7C	
						CRC low-Byte	CRC high-Byte

2. Set command baud rate to 19200 baud (BR=6)

Slave address	Function code	Starting address	Number Registers	Number byte(s)	Data	CRC	
0x01	0x10	0x9C 45	0x00 02	0x04	0x00 00 00 06	0x4E A4	
						CRC low-Byte	CRC high-Byte

6.3 Commands and Description

The following table lists the available commands and the associated passwords for read / write:

Command	Initial value factory setting	MODBUS register-address	Description	Password	
				Read ¹ / Write ²	
Command AI	10	40069	Averaging interval for wind speed and wind direction	None	User
Command BR	96	40005	Select baud rate	None	User
Command CI	0	40013	Command interpreter	None	User
Command DC	0	40081	Mode of calculation for twilight	None	User
Command DO	0	40037	North correction of wind direction	None	User
Command FB	1	40001	Quick-start mode	None	User
Command FP	33600513	40101	Parameter frost detection	None	User
Command FW	1500	40091	Sensitivity precipitation sensor	None	User
Command HP	5	40035	Heating power condensation protection	None	User
Command ID	0 (Thies) 1 (MODBUS)	4003	Identification number resp. slave address	None	User
Command IP	415282177	40103	Parameter ice detection	None	User
Command IS	3845	40107	Parameter ice detection	None	User
Command KY	0	40009	Set key / password	None	None
Command LC	0	40045	LED control	None	None
Command RH	-	40105	Rain history	None	None
Command RS	-	40029	Reset	None	User
Command SF	0	40075	Frame format	None	User
Command SH	0	40071	Station height	None	User
Command SP	265987	40099	Parameter snow detection	None	User
Command SV	-	45005	SW-Version	None	-
Command TR	-	-	Telegram output	None	None
Command TT	0	-	Automatic telegram output	None	None
Command TZ	0	40073	Time zone	None	User

Table 8 : List of Commands

1: Command without parameter (used to read selected parameter).

2: Command with parameter (used to write a new parameter).

Note:

All values of commands at Table 8 (exception KY and TR) are stored in the EEPROM. The number of memory cycles is limited, memory cycles >100000 can lead to a device defect.

6.3.1 Command AI

<id>AI<parameter><CR> Averaging interval for wind speed and wind direction

Access: Read / write.

Description: The command AI is used to specify the averaging interval for the wind speed and wind direction in minutes. The averaging of the wind velocity is scalar, and the averaging of the wind direction vectorial.

If the parameter is 0, the averaging is deactivated, and the mean values correspond to the instantaneous values. Here, the wind direction is reset (to 0°) during calm (< 0.6m/s).

Wind from the North is displayed with 360°.

Parameter description: AI = 0 → averaging disabled
AI = 1 → averaging interval = 1 minute

Value range: 0...10

Initial value: 10

6.3.2 Command BR

<id>BR<parameter><CR> Select baud rate

Access: Read / write.

Description: The command BR is used to select the required baud rate. See command SF.

Parameter description:

Parameter	Parameter	Description
12	2	1200baud
24	3	2400baud
48	4	4800baud
96	5	9600baud
192	6	19200baud
384	7	38400baud
576	8	57600baud
1152	9	115200baud

Value range: 12 / 24 / 48 / 96 / 192 / 384 / 576 / 1152

Initial value: 96

6.3.3 Command CI

<id>CI<parameter><CR> Selection of command interpreter

Access: Read / write.

Description: The requested command interpreter is set by command CL.

Remark:

If the identification number (ID) is > 98, it is set to 0 automatically with the change-over to the THIES interpreter!

Remark:

If the identification number (ID) equals 0, a change-over to the MODBUS-RTU-interpreter is not possible!

Parameter description:

Parameter	Description
0	THIES
1	MODBUS RTU

Value range: 0 to 1

Initial value: 0

6.3.4 Command DC

<id>DC<parameter><CR> Mode of calculation for twilight

Access: Read/ write.

Description: The mode of calculation for twilight is stated by command DC. The twilight is calculated from the 4 brightness values, depending on direction. Here, one can select between sum and mean value.

Parameter description: 0: Twilight corresponds to the sum of the 4 brightness values
1: Twilight corresponds to the mean value of the 4 brightness values

value rang: 0...1

Initial value: 0

6.3.5 Command DO

<id>DO<parameter><CR> North correction of wind direction
Access: Read / write.
Description: The command DO is used to specify an offset for the wind direction in °. This brings about correction to the north for the Weather Station.
Value range: 0...360
Initial value: 0

6.3.6 Command FB

<id>FB<parameter><CR> Quick-start mode
Access: Read / write.
Description: The command FB is used to select quick-start mode.
Parameter description: 0: quick-start mode disabled
1: quick-start mode enabled
Value range: 0...1
Initial value: 1

6.3.8 Command FW

<code><id>FF<parameter><CR></code>	Sensitivity precipitation sensor
Access	Read / write.
Description:	<p>Precipitation detection is capacitive, which means that the capacity depends on the surface of the sensor that is wetted with water. In the weather station, the capacity is measured indirectly via a frequency measurement. In the dry state, the frequency is approx. 38kHz and decreases with increasing wetting. If the sensor surface is completely wetted, the frequency is approx. 17kHz.</p> <p>The "FW" command is used to set the sensitivity of the precipitation sensor. The specification is in ppm and designates the threshold (frequency deviation between the instantaneous value and the moving average over 5s) for the detection of precipitation.</p>
Parameter description:	<p>100: high sensitivity, i.e. even a small wetted area is recognized as precipitation</p> <p>2000: low sensitivity, i.e. only a large wetted area is recognized as precipitation</p> <p>A drop with a diameter of approx. 2mm corresponds to a value change of approx 380 increments.</p>
Value Range:	100...20000
Initial value:	1500

6.3.9 Command HP

<code><id>HP<parameter><CR></code>	Heating power condensation protection
Access:	Read / write.
Description:	The heating capacity for the condensation protection of the precipitation monitor is set by command "HP". The indication is stated in percent.
Parameter description:	<p>5...8: Maximum responsivity of the precipitation monitor for detection of the lowest precipitation intensities.</p> <p>9...17: High responsivity, and at the same time reduction of the responsivity for fog, mist and condensation.</p> <p>18...22: Maximum insensibility against fog, mist and condensation</p>
Value range:	0...100
Initial value:	5

6.3.10 Command ID

<id>ID<parameter><CR>	Identification number
Access:	Read / write.
Description:	This command is used to specify the identification number (THIES interpreter) resp. the slave address (MODBUS RTU Interpreter). A response telegram will only be transmitted if the 'id' in the command matches the one set in the Weather Station. An exception here is the generic 'id' that causes all weather stations to respond. Once the 'id' has been changed, the device will immediately respond with the new 'id'.
Parameter description:	99 generic 'id' (THIES interpreter) 0 Broadcast slave address (MODBUS RTU Interpreter)
Value range:	0 to 99 (THIES interpreter) 1 to 247 (MODBUS RTU interpreter)
Initial value:	0 (THIES Interpreter) 1 (MODBUS RTU Interpreter)

6.3.11 Command IP

<id>IP<parameter><CR> Parameter ice detection

Access: Read / write.

Description: The "IP" command is used to set the sub-parameters for ice detection. The "IP" parameter comprises 32 bits and contains the 4 bit-coded sub-parameters "ON delay", "OFF delay", "Temperature threshold" and "RAIN history".

Parameter description:

31								24									16									8							0
RAIN history (6Bit)								Temp. Threshold (5Bit)								OFF delay (12Bit)								ON delay (8Bit)									

ON delay

- 8Bit unsigned
- Bereich: 0...255 [min]
- Default: 1 [min]

OFF delay

- 12Bit → 16Bit unsigned
- Bereich: 0...3000 [min]
- Default: 180 [min]

Temp. Threshold

- 5Bit → -10 and Typecast in 8Bit with sign
- Range: -10...6 [°C]
- Default: 2 [°C]

RAIN history

- 6Bit → 8Bit unsigned
- Range: 0...48 [h]
- Default: 12 [h]

Value range: see parameter description

Initial value: 415282177 (ON delay=1min, OFF delay=180min, Temp. Threshold=2°C, Rain history=12h)

6.3.14 Command LC

<id>LC<parameter><CR> LED control

Access: Read / write.

Description: The command LC is used to specify the mode for control of the blue LED.

Parameter description:

Parameter	Description
0	LED (blue) indicates wind speed
1	LED (blue) is dark

Examples:

LED dark blue: "00LC1\r"

LED blue indicates wind speed: "00LC0\r"

Value range: 0 / 1

Initial value: 0

6.3.15 Command RH

<id>RH<parameter><CR> Rain history

Access: Read / write.

Description: The "RH" command can be used to reset the rain history for ice detection (IP command, "RAIN history" subparameter).

Parameter description: 1 Reset the rain history

Value range: 1

Initialwert: -

6.3.16 Command RS

<id>RS<parameter><CR> Reset

Access: Read / write.

Description: Through the command RS a reset of the microcontroller is carried out. The cause for the last reset is output without stating a parameter. Here, the output occurs in the form of strings (see the following table), which are lined up in a row, separated by spaces.

String	Description
PORF	Power On Reset Flag
EXTRF	External Reset Flag
BORF	Brownout Reset Flag
WDRF	Watchdog Reset Flag
PDIRF	Programming/Debug Interface Reset Flag
SRF	Software Reset Flag
SDRF	Spike Detector Reset Flag

Parameter description: 1 Watchdog reset
2 Software reset

Value range: 1 / 2

Initial value: -

6.3.17 Command SF

<id>SF<parameter><CR> Frame format

Access: Read / write.

Description: This command is used to set the frame format of the weather station.

Parameter description: 0: 8N1 (8 data bits, no parity, 1 stop bit)
1: 8N2 (8 data bits, no parity, 2 stop bits)
2: 8E1 (8 data bits, even parity, 1 stop bit)
3: 8E2 (8 data bits, even parity, 2 stop bits)
4: 8O1 (8 data bits, uneven parity, 1 stop bit)
5: 8O2 (8 data bits, uneven parity, 2 stop bits)

Value range: 0...5

Initial value: 0

6.3.18 Command SH

<id>SH<parameter><CR> Station height

Access: Read / write.

Description: The command is used to select the altitude at the location where the Weather Station is installed. This value is used to calculate the relative air pressure. Height is specified in metres. If the set parameter is 3001, the relative air pressure with elevation is calculated from the GPS data.

Parameter description: Height above MSL in metres

0...3000: Station height in metres (the basis for calculation of the relative air pressure)

3001: The parameter SH is disregarded (calculation of the relative air pressure is based on the height from the GPS data)

Value range: 0...3001

Initial value: 0

Remark: GPS determines ellipsoidal heights above the reference ellipsoid (==> World Geodetic System WGS84). From 36m (in Western Pomerania) up to 50m (in the Black Forest and in the Alps) the ellipsoidal heights in Germany are higher than the heavy-related heights (NN, HN, NHN).

That means, there are regional elevation errors which can be avoided by manual entry.

Moreover, it must be considered that the GPS altitude values can be subject to a change of up to 30m (referred to the WGS84 ellipsoid).

6.3.19 Command SP

<id>SP<parameter><CR> Parameter snow detection

Access: Read / write.

Description: The "SP" command is used to set the sub-parameters for snow detection. The "SP" parameter comprises 32 bits and contains the 3 bit-coded sub-parameters "ON delay", "OFF delay" and "Temperature threshold".

Parameter description:

31																	24																16																		8																																						0
unused								Temp. Threshold (8Bit)								OFF delay (8Bit)								ON delay (8Bit)																																																																	

ON delay

- 8Bit unsigned
- Bereich: 0...60 [s]
- Default: 3 [s]

OFF delay

- 8Bit unsigned
- Bereich: 0...255 [min]
- Default: 15 [min]

Temp. Threshold

- 8Bit with sign
- Bereich: -10...6 [°C]
- Default: 4 [°C]

Value range: See parameter description

Initial value: 265987 (ON delay=3s, OFF delay=15min, Temp. Threshold=4°C)

6.3.20 Command SV

<id>SV<CR> SW-Version

Access: Read.

Description: The software version can be read by means of command SV.

Parameter description: -

Response telegram: -

Value range: -

Initial value: -

6.3.21 Command TR

<id>TR<parameter><CR>	Telegram output
Access:	Read / write.
Description:	This command initiates one-off transmission of a telegram. The parameter specifies the type of telegram.
Parameter description:	1 Measured value telegram. 2 Sensor data telegram.
Response telegram:	See section 0
Value range:	1...2
Initial value:	-

6.3.22 Command TT

<id>TT<parameter><CR>	Automatic telegram output
Access:	Read / write.
Description:	The command TT is used to select the automatic output of telegrams (interval = 1 second). Automatic telegram output remains switched off for the first 10 seconds after start-up of the Weather Station. During this time the user has the opportunity of changing the parameter TT.
Parameter description:	0 Automatic telegram output switched off. 1 Measured value telegram. 2 Sensor data telegram.
Response telegram:	See section 0
Value range:	0...2
Initial value:	0

6.3.23 Command TZ

<id>TZ<parameter><CR> Time zone

Access: Read / write.

Description: The command TZ is used to change the output of date/time.

Parameter description::

- 0 UTC
- 23: UTC-Zeit – 1 hours
- 24: UTC-Zeit
- 25: UTC-Zeit + 1 hours
- 48: CEST or CET

The change between summer- and winter time occurs independently.

TZ	Signification
0	UTC
1	UTC – 23 hours
...	...
24	UTC
...	-1
47	UTC + 23 hours
48	CEST or CET

Response telegram: -

Value range: 0...48

Initial value: 0

7 LED Signals

On the underside of the COMPACT WSC11 Weather Station there are 2 LEDs which are externally visible through the housing.

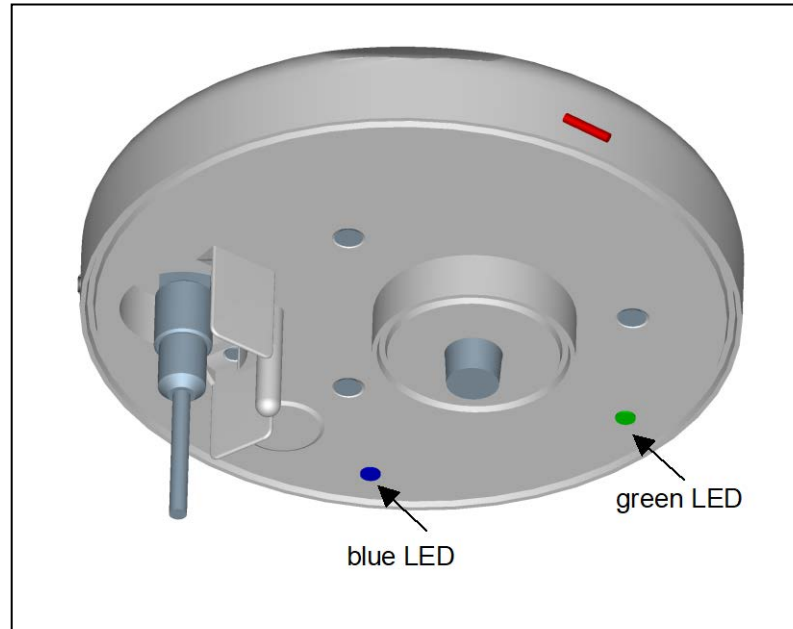
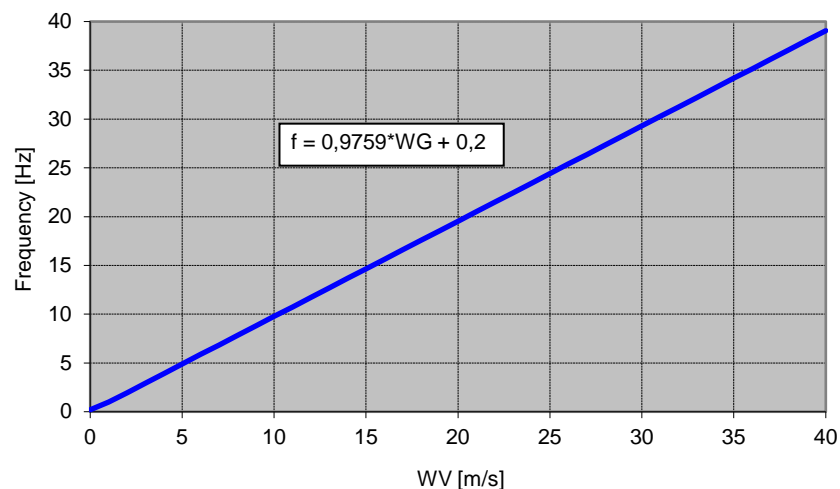

Figure 3: LED signals

If the Weather Station does not receive a command to query measured values for 3 seconds or longer, the green LED flashes at a frequency of 1Hz and signals its readiness for operation. If automatic telegram output is enabled (see **Command TT**), the green LED remains dark.

The flash frequency of the blue LED indicates the current wind speed (see **Command LC**). The correlation between the flash frequency and wind speed is shown in the following figure:

Flash frequency of blue LED as a function of wind velocity



8 Specifications

Wind speed		
	Type	Thermal anemometer
	Measuring range	0 ... 40m/s
	Resolution	0.1m/s
	Accuracy	To 10m/s: ±1m/s (rms - mean over 360°) From 10m/s: ±5% (rms - mean over 360°)
Wind direction		
	Type	Thermal anemometer
	Measuring range	1 ... 360°
	Resolution	1°
	Accuracy with laminar incident flow	±10°
Brightness		
	Type	Silicon sensor
(north, east, south, west)	Measuring range	0 ... 150kLux
	Resolution	0.1kLux
	Accuracy	±3% (± 4.5kLux)
	Spectral range	475 ... 650nm
Twilight		
	Type	Silicon sensor
	Measuring range	0 ... 999Lux
	Resolution	1Lux
	Accuracy	±10Lux
Global irradiance		
	Type	Silicon sensor
	Measuring range	0 ... 1300W/m ²
	Resolution	1W/m ²
	Accuracy	±10% (± 130W/m ²)
	Spectral range	350 ... 1100nm
Precipitation		
	Type	Ceramics, capacitive value measurement, sensor area heated
	Measuring status	1 / 0 (precipitation yes/no)
	Measuring intensity	0...15mm/h
	Resolution	0,001mm/h
	Measuring quantity	0...999,999mm
	Resolution	0,001mm

	Thermal output, sensor dry, be-dewing protection	0.1W
	Thermal output, sensor wet drying phase	1.1W
Temperature		
	Type	PT1000
	Measuring range	-30 ... +60°C
	Resolution	0.1°C
	Accuracy with wind speed >2m/s	±1°C (-5 ... +25°C)
Air pressure sensor		
	Type	Piezoresistive
	Measuring range	300 ... 1100hPa
	Resolution	0.01hPa
	Accuracy	±0.5hPa at 20°C
	Long-term stability	±0.1hPa / year
Humidity sensor		
	Type	CMOS capacitive
Relative humidity		
	Measuring range	0 ... 100% rel. humidity
	Resolution	0.1% rel. humidity
	Accuracy with wind speed >2m/s	±10% rel. humidity at 20°C
Absolute humidity		
	measuring range	0 ... 400g/m ³
	Resolution	0.01g/m ³
Dew-point temper-ature		
	Measuring range	-30 ... +60°C
	Resolution	0.1°C
Inside temperature of housing		
	Type	Silicon sensor
	Measuring range	-30 ... +60°C
	Resolution	0.1°C
	Accuracy	±2°C
Digital interface		
	Type	RS485
	Mode	Half-duplex mode
	Baud rate	1200, 2400, 4800, 9600 , 19200, 38400, 57600, 115200
	Data format	- ASCII (command interpreter: THIES) - Binary (command interpreter: MODBUS RTU)

General		
Operating voltage		18 ... 30VDC, 18 ... 28VAC
	Power consumption	120mA @ 24V (max. 1,5A AC, max 0,5A DC)
Ambient conditions	Temperature range	-30 ... +60°C
	Humidity range	Non-condensing
To avoid false-positive Precipitation outputs, the setting HP=20 is recommended when used in humid and hot climates (RH>85% @ air temperature>35°C).		
GPS reception	GPS receiver with low power consumption, built-in RTC and antenna	
	Holding time of RTC (without voltage supply)	Approx. 3 days
Housing	Material	Polycarbonate
	Dimensions	See Dimension drawing
	Weight	0.22kg
	Type of protection	IP65 in working position
	Type of connection	7-pin plug connector

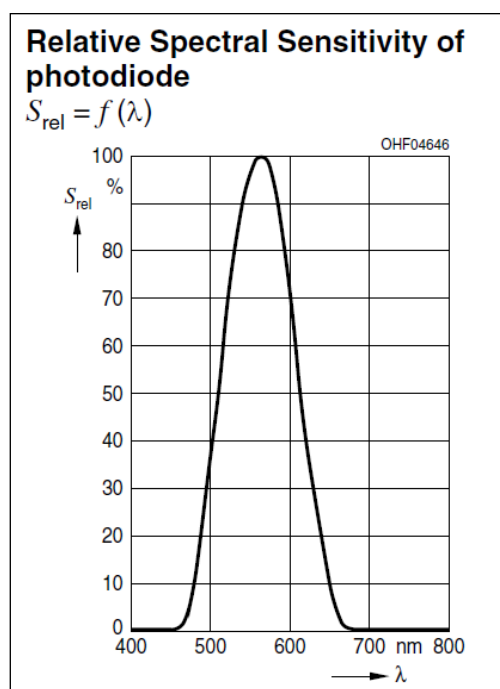

Figure 4: Spectrum of Brightness Sensors

(Source: data sheet for component SFH5711 / OSRAM)

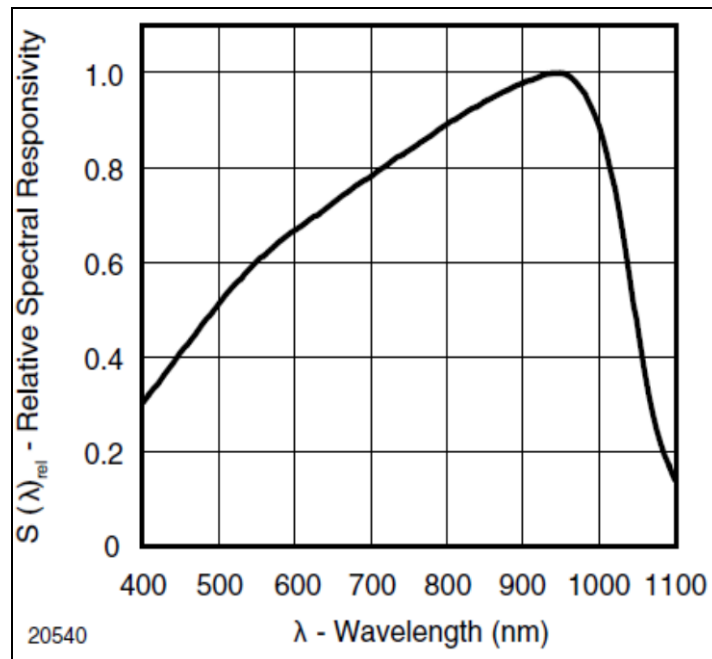
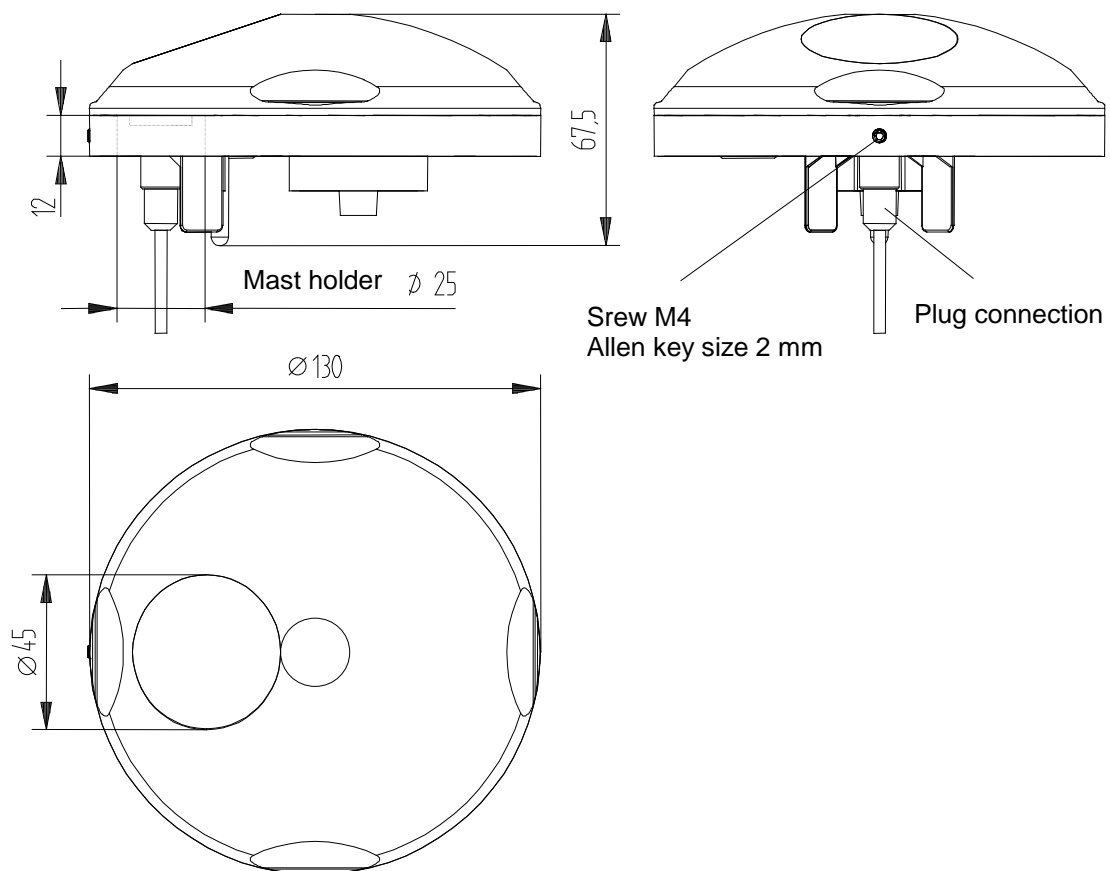

Figure 5: Spectrum for Global Irradiance Sensor

(Source: data sheet for component TEMD5080X01 / VISHAY)

9 Dimensional Drawing



10 Accessories (optional)

Cable Prepared connecting cable for COMPACT WSC11 Weather Station. Features: Cable with cable socket on device side and open ends on reception side.	Article No. 510023 Article No. 510024 Article No. 510197	Length: 5m Length: 10m Length: 20m
Device Utility Tool	Article No. 9.1700.81.000	Cost-free tool for parameter settings and/or special configurations. Please send a short e-mail to info@thiesclima.com , keyword "Utility Tool WSC 11" in the subject heading, as well as your sender information and our order number / invoice number. We will then let you have your log-in for the download.
Installation support Used for lateral attachment of COMPACT WSC11 Weather Station to a vertical surface.	Article No. 509564	Length: 250mm Width: 60mm Material: Stainless steel 1.4301

11 More Information / Documents as download

Further information can be found in the short instructions for use. These document and also the short instruction for use are available for download under the following links.

Short instruction for use

https://www.thiesclima.com/db/dnl/4.9056.10.x0x_WSC11_eng_short.pdf

Instruction for Use

https://www.thiesclima.com/db/dnl/4.9056.10.x0x_WSC11_eng.pdf

12 EC-Declaration of Conformity

Manufacturer: Adolf Thies GmbH & Co. KG
 Hauptstraße 76
 37083 Göttingen, Germany
<http://www.thiesclima.com>

Product: Weatherstation Compact WSC11

Doc. Nr. 2002-45223_CE

Article Overview:

4.9056.10.000 4.9056.10.001 4.9056.10.501 4.9056.10.601 4.9056.10.701 4.9056.10.801 4.9056.11.001

The indicated products correspond to the essential requirement of the following European Directives and Regulations:

2014/30/EU	26.02.2014	DIRECTIVE 2014/30/EU OF THE EUROPEAN PARLIAMENT AND OF THE COUNCIL of 26 February 2014 on the harmonisation of the laws of the Member States relating to electromagnetic compatibility.
2017/2102/EU	15.11.2017	DIRECTIVE (EU) 2017/2102 of the European Parliament and of the Council of November 15, 2017 amending Directive 2011/65 / EU on the restriction of the use of certain hazardous substances in electrical and electronic equipment.
2012/19/EU	13.08.2012	DIRECTIVE 2012/19/EU OF THE EUROPEAN PARLIAMENT AND OF THE COUNCIL of 4 July 2012 on waste electrical and electronic equipment (WEEE).
2018/1139/EU	04.07.2018	Regulation (EU) 2018/1139 of the European Parliament and of the Council of 4 July 2018 on common rules in the field of civil aviation and establishing a European Union Aviation Safety Agency.

The indicated products comply with the regulations of the directives. This is proved by the compliance with the following standards:

DIN EN IEC 61000-6-2	2019-11	Electromagnetic compatibility Immunity for industrial environment
DIN EN 61000-6-3:2007 + A1:2011	2011-09	Electromagnetic compatibility (EMC). Generic standards. Emission standard for residential, commercial and light-industrial environments
DIN EN 61010-1	2020-03	Safety requirements for electrical equipment for measurement, control, and laboratory use. General requirements
DIN EN IEC 63000	2019-05	Technical documentation for the assessment of electrical and electronic products with respect to the restriction of hazardous substances.

Göttingen, 24.10.2023



General Manager - Dr. Christoph Peper



Development Manager - ppa. Jörg Peterleit

This declaration of conformity is issued under the sole responsibility of the manufacturer.

This declaration certifies the compliance with the mentioned directives, however does not include any warranty of characteristics.

Please pay attention to the security advises of the provided instructions for use.

13 UK-CA-Declaration of Conformity

Manufacturer: Adolf Thies GmbH & Co. KG
 Hauptstraße 76
 37083 Göttingen, Germany
<http://www.thiesclima.com>

Product: Weatherstation Compact WSC11

Doc. Nr. 2002-45223_CA

Article Overview:

4.9056.10.000 4.9056.10.001 4.9056.10.501 4.9056.10.601 4.9056.10.701 4.9056.10.801 4.9056.11.001

The indicated products correspond to the essential requirement of the following Directives and Regulations:

1091	08.12.2016	The Electromagnetic Compatibility Regulations 2016
RoHS Regulations 2012	01.01.2021	The Restriction of the Use of Certain Hazardous Substances in Electrical and Electronic Equipment Regulations 2012
3113	01.01.2021	Regulations: waste electrical and electronic equipment (WEEE)
2018/1139/EU	04.07.2018	Regulation (EU) 2018/1139 of the European Parliament and of the Council of 4 July 2018 on common rules in the field of civil aviation and establishing a European Union Aviation Safety Agency.

The indicated products comply with the regulations of the directives. This is proved by the compliance with the following standards:

BS EN IEC 61000-6-2	25.02.2019	Electromagnetic compatibility (EMC). Generic standards. Immunity standard for industrial environments
BS EN IEC 61000-6-3	30.03.2021	Electromagnetic compatibility (EMC). Generic standards. Emission standard for equipment in residential environments
BS EN 61010-1+A1	31.03.2017	Safety requirements for electrical equipment for measurement, control, and laboratory use. General requirements
BS EN IEC 63000	10.12.2018	Technical documentation for the assessment of electrical and electronic products with respect to the restriction of hazardous substances

Göttingen, 24.10.2023

Legally binding signature:



General Manager - Dr. Christoph Peper

Legally binding signature:



Development Manager - ppa. Jörg Peterreit

This declaration of conformity is issued under the sole responsibility of the manufacturer.

This declaration certifies the compliance with the mentioned directives, however does not include any warranty of characteristics.

Please pay attention to the security advises of the provided instructions for use.

**Please contact us for your system requirements.
We advise you gladly.**

ADOLF THIES GMBH & CO. KG

Meteorology and environmental metrology
Hauptstraße 76 · 37083 Göttingen · Germany
Phone +49 551 79001-0 · Fax +49 551 79001-65
info@thiesclima.com

www.thiesclima.com

